

**ANNEX 11 – EQUIPMENT/SADDLERY REFERENCE**

This annex is to be used as a reference to Article 428 and must only be used in conjunction with the written rules which take precedence over this annex. The images below are examples only, and similar equipment which produce the same effect on the horse are also allowed if they adhere to the written rules.

Saddles

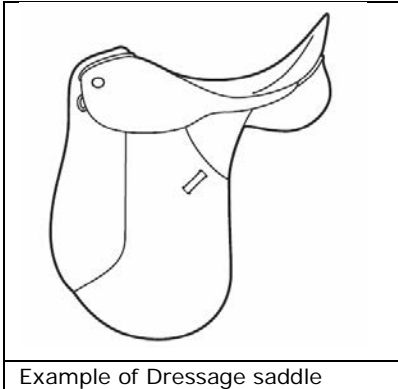

Example of Dressage saddle

Bridles

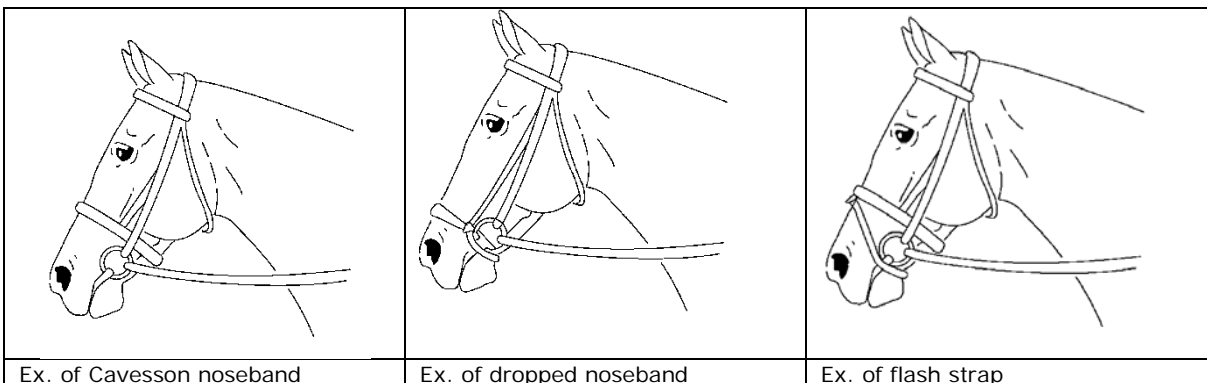
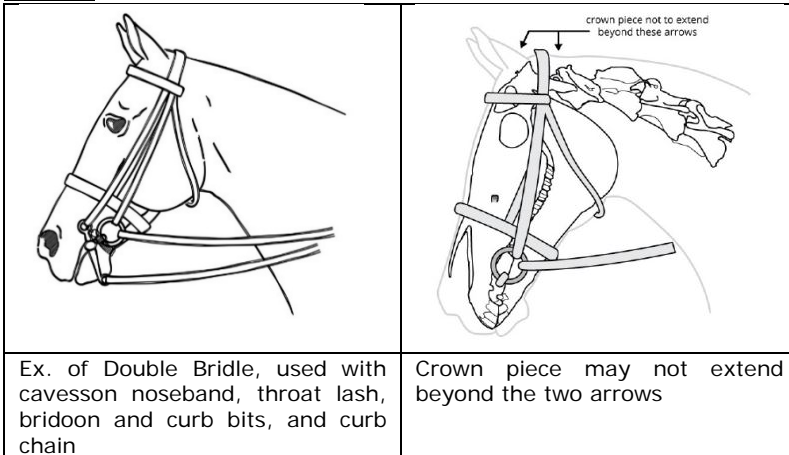

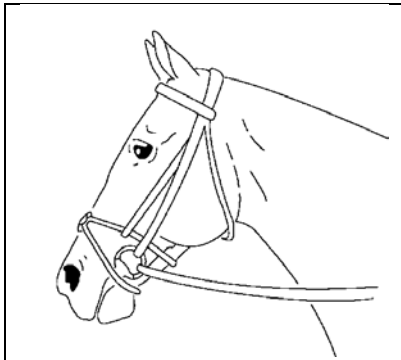
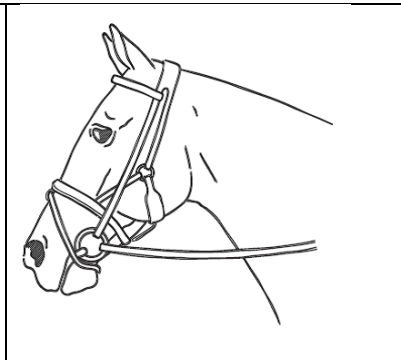
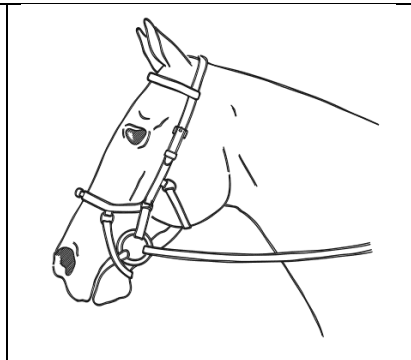
		
Ex. of crossed/mexican/grackle noseband	Ex. of combined noseband – no throat lash necessary	Ex. of Micklem style bridle – no throatlash necessary

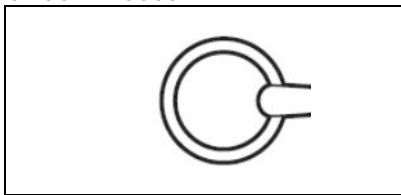
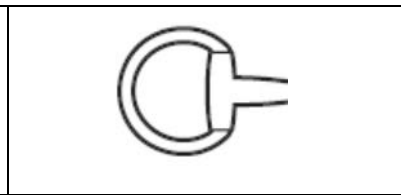
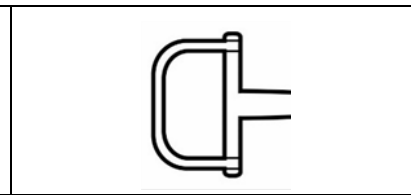
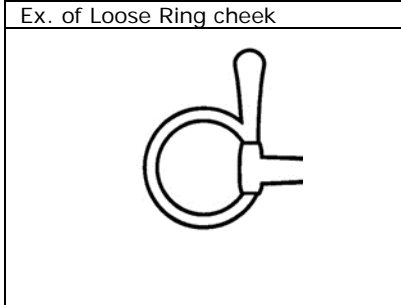
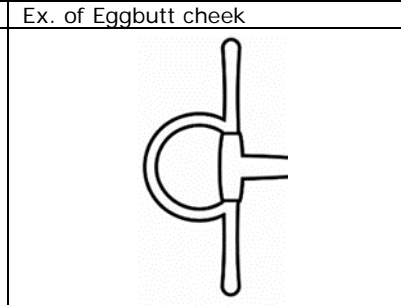
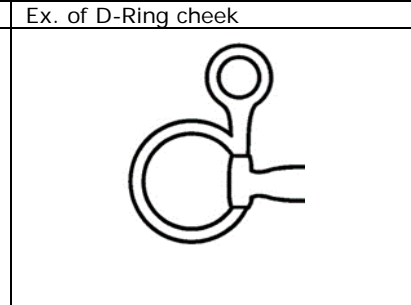
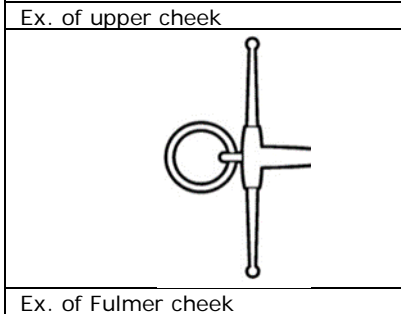

**Bits**

Cheek Pieces:

		
Ex. of Loose Ring cheek	Ex. of Eggbutt cheek	Ex. of D-Ring cheek
		
Ex. of upper cheek	Ex. of full cheek	Ex. of hanging cheek
		
Ex. of Fulmer cheek		

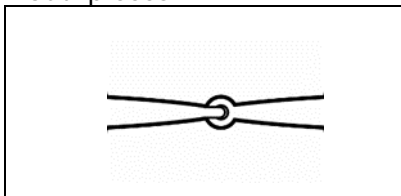
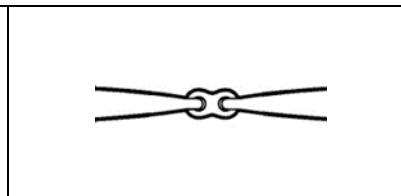
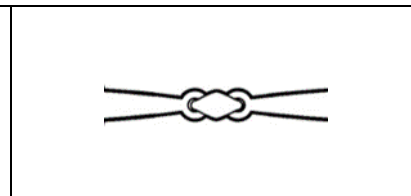
Mouthpieces:

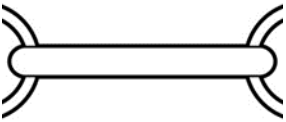
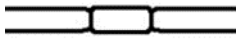
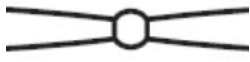

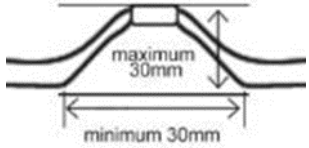

		
Ex. of single jointed mouthpiece	Ex. of double jointed mouthpiece	Ex. of double jointed mouthpiece

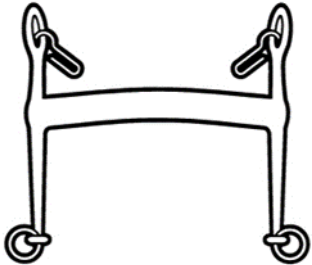
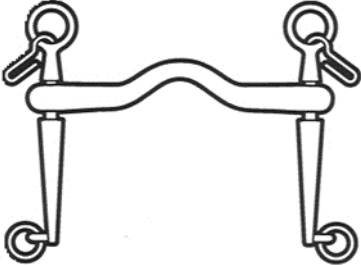
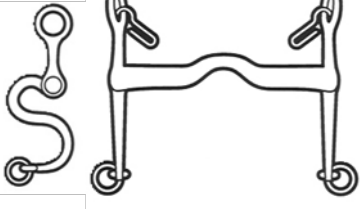
		
Ex. of unjointed mouthpiece	Ex. of barrel joint	Ex. of ball joint
		
Ex. of double ball joint	Ex. of centrepiece with a roller	Port deviation measurements

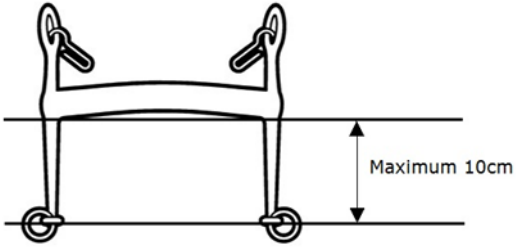
Curb Bits:

		
Ex. of curb with straight cheeks	Ex. of curb with port and sliding mouthpiece (rotating arms also allowed)	Ex. of curb with S cheeks

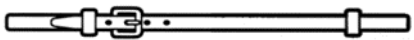
Maximum size of lever arm

	
Ex. of Curb chain	Ex. of Leather cover for curb chain
	
Ex. of lip strap	Ex. of cover for curb chain